

# INCEPTOR® HION

## Technical Specification

Product Code: OV100100EM

Description: 100W LED 1-10V Dimmable Highbay With Emergency - IP65 - 4000K - Black

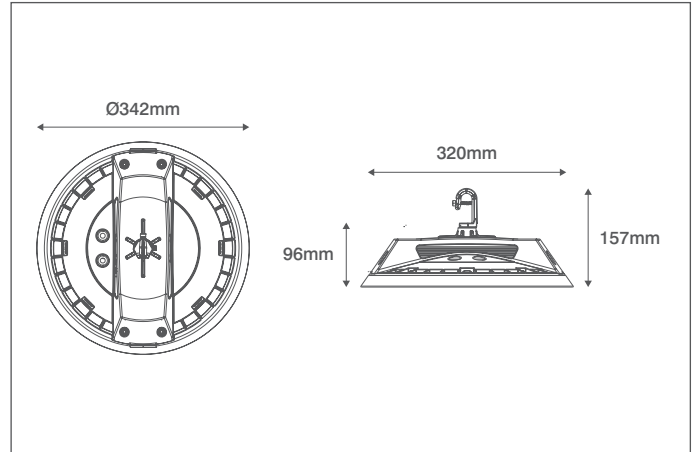

### General Information

Highbay Dimensions	342mm Diameter x 157mm (D) (With Hook)
Materials	Highbay Body: Powdercoated Aluminium Highbay Diffuser: Polycarbonate EM Pack Cover: Polycarbonate EM Pack Base: Powdercoated Steel
Finish	Black (RAL 9004)
Product Weight	5.15Kg
Dimmable	Yes - 0(1)-10V
Ingress Protection	IP65
IK Rating	IK10
Hook Thread	G1/2 x 19.8mm
Warranty	6 Years (4 Years Battery)

### Supply & Power

Input Voltage & Frequency	220-240V~ 50/60Hz
Electrical Safety	Class I
LED Wattage	100W
Circuit Wattage	105W
Inrush Current	29.2A (640µs)
Ambient Temperature (Ta)	0°C - +40°C (Emergency Pack)
Critical Temperature	+50°C (Emergency Pack)
Input Mains	1 Metre Flylead From Emergency Pack
0(1)-10V Input Cable	2 x 20 AWG (3 Metres) - Black

### Accessories

OVWB1092	Bracket For 100W & 150W Inceptor® Hion Highbay Fittings
OVEMCL05	Highbay Emergency Pack Coupler Leads – 0.5M (Pair)
OVEMCL1	Highbay Emergency Pack Coupler Leads – 1M (Pair)
OVHBDACV	High Bay IP67 DALI Signal Converter

### Luminaire Output

Colour Temperature	4000K
CRI	70
Typical Luminous Flux	14630lm
Efficacy	144lm/W
Beam Angle	90°
LED Lifetime (L70)	54,000 Hours

### Emergency Information

Input Current	<80mA Max.
Output Voltage	<55V DC
Battery Specification	4.8V 4Ah Ni-Cd
Installation Requirements	Maintained
Emergency Duration	3 Hours Minimum
Dimensions	380mm (L) x 123mm (W) x 56.5mm (H)

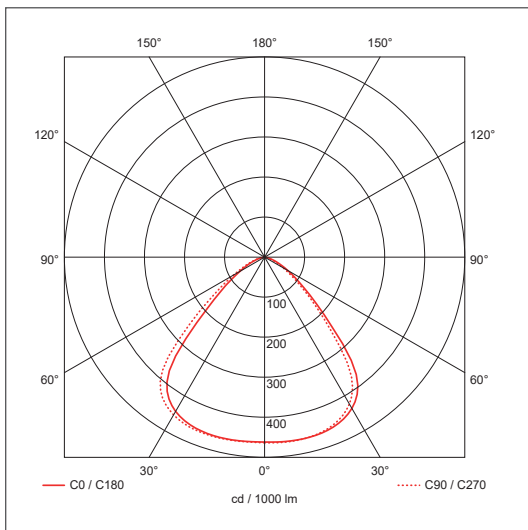

Ovia Limited, Scolmore House, Mariner, Lichfield Road Industrial Estate, Tamworth, Staffordshire, B79 7UL United Kingdom

T: +44 (0)1827 300640

E: sales@oviaUK.com | W: oviaUK.com